

Rindge Building Department  
 30 Payson Hill Rd, PO Box 163  
 Rindge NH 03461  
 Phone: 603-899-5181 Ex 109  
 Fax: 603-899-2101  
 buildingdept@town.rindge.nh.us

Map # \_\_\_\_\_  
 Lot # \_\_\_\_\_  
 Zoning: \_\_\_\_\_  
 Date: \_\_\_\_\_

**Minimum Setbacks:**

District	FRONT / RIGHT of WAY	SIDE / REAR	WETLAND / LAKE FRONT
Residential	50 Feet	15 Feet	50 Feet
Residential / Agricultural	50 Feet	30 Feet	50 Feet
Village	50 Feet	15 Feet	50 Feet
Commercial / Light Industry	Contact Planning	Contact Planning	50 Feet
Commercial	Contact Planning	Contact Planning	50 Feet
College	75 Feet	Contact Planning	50 Feet
Gateway	25 Feet	Contact Planning	50 Feet

**Steps To Obtain Accessory Permit**

- Complete Page 1 & 2 of this Guide
- Fill Out Building Permit Application Package
- Provide Stamped Truss Specs for all Engineered Roof & Floor Trusses and Manufactured Beam
- Submit All Forms To Building Department With Payment

**A site plan must accompany the application for the Addition (Page 4 of Application)**

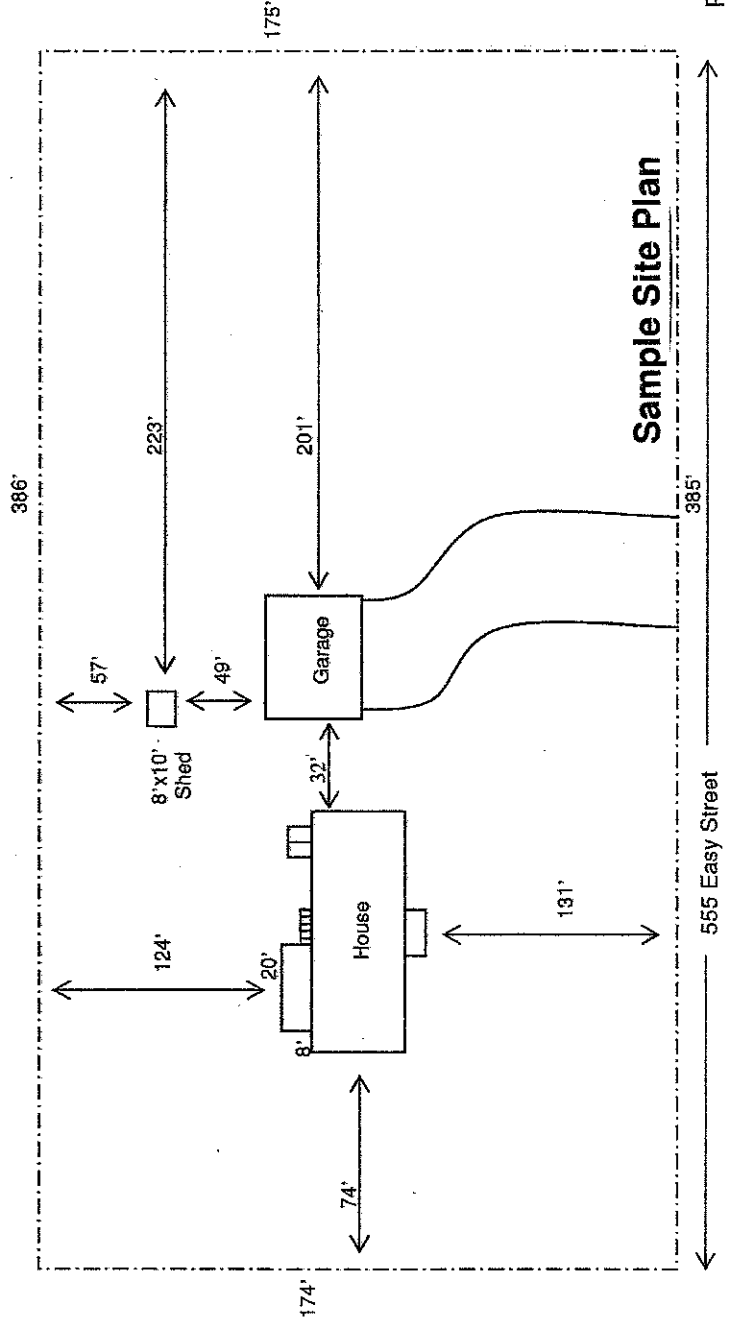

555 Easy Street